

# PD8 Series ProtEX-MAX Supplemental Instruction Manual



**ProtEX**<sup>TM</sup>  
MAX



- Modern, Sleek and Practical Enclosure
- Display Mountable at 0°, 90°, 180°, & 270° Degrees
- Explosion-Proof, IP68, NEMA 4X Enclosure
- PROVU<sup>®</sup>, Trident X2, Snooper or Vigilante<sup>®</sup> II Functionality
- SafeTouch<sup>®</sup> Through-Glass Button Programming
- Flanges for Wall or Pipe Mounting
- Modbus<sup>®</sup> RS-485 Serial Communications Standard on Most Models
- Free MeterView<sup>®</sup> and MeterView<sup>®</sup> Pro Software
- All Models Available with Sunlight Readable Displays

**PRECISION DIGITAL CORPORATION**  
89 October Hill Road • Holliston MA 01746 USA  
Tel (800) 343-1001 • Fax (508) 655-8990

**PRECISION  
DIGITAL**

[www.predig.com](http://www.predig.com)

### Disclaimer

The information contained in this document is subject to change without notice. Precision Digital makes no representations or warranties with respect to the contents hereof; and specifically disclaims any implied warranties of merchantability or fitness for a particular purpose.

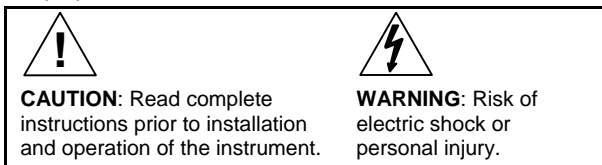

### Warning

- This product is not recommended for life support applications or applications where malfunctioning could result in personal injury or property loss. Anyone using this product for such applications does so at his/her own risk. Precision Digital Corporation shall not be held liable for damages resulting from such improper use.
- Failure to follow installation guidelines could result in death or serious injury. Make sure only qualified personnel perform the installation.
- Never remove the instrument cover in explosive environments when the circuit is live.
- Cover must be fully engaged to meet flameproof/explosion-proof requirements.
- Information in this manual supersedes all enclosure, compliance, and agency approval information included in additional product manuals included with this product.

### Limited Warranty

Precision Digital Corporation warrants this product against defects in material or workmanship for the specified period under "Specifications" from the date of shipment from the factory. Precision Digital's liability under this limited warranty shall not exceed the purchase value, repair, or replacement of the defective unit.

### Registered Trademarks

All trademarks mentioned in this document are the property of their respective owners.

© 2011-2013 Precision Digital Corporation. All rights reserved.

**[www.predig.com](http://www.predig.com)**

### INTRODUCTION

The ProtEX-MAX has been designed to offer the functions and features of any PROVu, Trident X2, Snooper, or Vigilante II model in a great looking full-approved explosion-proof product. The PD8 series is not just an 1/8 DIN meter mounted in an explosion-proof housing. A special bezel and electronics were designed exclusively for the ProtEX-MAX. The bezel and faceplate give the front panel a very finished appearance and house the additional electronics for the PD8. The user has the ability to program and operate the instrument without opening the housing using the built-in SafeTouch through-glass button programming or serial communications port with free Modbus protocol included (serial communications not present on PD8-154 or PD8-158 Series models).

### How to Use this Manual

This ProtEX-MAX includes this manual addendum and a complete panel meter instruction manual for a PROVu, Trident X2, Snooper, or Vigilante II. This manual addendum combines with the additional included manual to provide you complete product information. This manual contains all the information on the ProtEX-MAX enclosure, SafeTouch through-glass button programming, and the on-board functions that may include RS-485 serial communications, digital inputs, digital outputs, and other features not included in the base model. These features have electrical wiring connections on the round board mounted to the rear of the electronics housing..



**NOTICE**

Information in this manual supersedes all enclosure, compliance, and agency approval information included in additional product manuals included with this product.

For information on programming your product, the user interfaces, or general instrument specifications, please refer to the PROVu, Trident X2, Snooper, or Vigilante II instruction manual included with this ProtEX-MAX.

*Example:* A PD8-6000-6R2 will include this manual as well as the PD6000 PROVu instruction manual (LIM6000).

Refer to the PROVu PD6000 manual for all setup, programming, and most electronics specifications. Refer to this manual for operation of the SafeTouch through-glass button programming, on-board RS-485 connections, digital inputs/outputs, enclosure information, and all approvals.



**NOTICE**

For PD8-6xxx/7xxx models only:  
Transmitter supplies rated @ 25 mA max each

## MODEL NUMBER DESCRIPTIONS

Model	Description	Integrated Functionality
PD8-154	4 Point Alarm Annunciator	Vigilante II PD154
PD8-158	8 Point Alarm Annunciator	Vigilante II PD158
PD8-765	Large Display Universal Input Meter	Trident X2 PD765
PD8-865	Modbus Serial Input Meter	Snooper PD865
PD8-6000	Process Meter	PROVu PD6000
PD8-6060	Dual-Input Process Meter	PROVu PD6060
PD8-6100	Strain Gauge Meter	PROVu PD6100
PD8-6200	Analog Input Rate/Totalizer	PROVu PD6200
PD8-6210	Analog Input Batch Controller	PROVu PD6210
PD8-6262	Dual Analog Input Batch Controller	PROVu PD6262
PD8-6300	Pulse Input Rate/Totalizer	PROVu PD6300
PD8-6310	Pulse Input Batch Controller	PROVu PD6310
PD8-6363	Dual Pulse Input Rate/Totalizer	PROVu PD6363
PD8-7000	Temperature Meter	PROVu PD7000

### Ordering Configuration Example

The model number of a PD8 Series ProtEX-MAX is in the format of PD8- followed by the numeric model number of the product whose features the ProtEX-MAX shares.

*Example:* A PD8-6000-6R2 is the model number of a dual-line process meter with the features and options of a PD6000-6R2; all PD6000 PROVu features with AC line power and 2 relays.

#### PROVu Based Configuration Example

**PD8** - 

6	0	0	0
---	---	---	---

 - 

6	R	2
---	---	---

Any PROVu Model
-----------------

#### Trident X2 Based Configuration Example

**PD8** - 

7	6	5
---	---	---

 - 

6	X	2
---	---	---

 - 

1	0
---	---

Any Trident X2 Model
----------------------

#### Snooper Based Configuration Example

**PD8** - 

8	6	5
---	---	---

 - 

6	R	7
---	---	---

 - 

1	6
---	---

Any Snooper Model
-------------------

#### Vigilante II Based Configuration Example

**PD8** - 

1	5	4
---	---	---

 - 

6	R	2
---	---	---

 - 

1
---

Any Vigilante II Model
------------------------

## Table of Contents

<b>INTRODUCTION</b>	<b>3</b>
<b>MODEL NUMBER DESCRIPTIONS</b>	<b>4</b>
<b>SPECIFICATIONS</b>	<b>7</b>
Instrument Specifications	7
General	7
Serial Communications	7
Digital Inputs & Outputs	8
External Switch Contacts	8
Product Ratings and Approvals;	9
Electromagnetic Compatibility	11
<b>SAFETY INFORMATION</b>	<b>12</b>
<b>INSTALLATION</b>	<b>12</b>
Unpacking	13
Pre-Installed Conduit/Stopping Plug	13
Mounting	13
Cover Jam Screw	13
<b>CONNECTIONS</b>	<b>14</b>
Required & Factory Wired Connections	14
Digital I/O Connections	21
External Switch Contacts	22
Serial Communications Connections	24
Using ProVu Serial Adapters	27
<b>OPERATION</b>	<b>28</b>
Overview	28
SafeTouch Buttons	28
Digital I/O	29
Serial Communications Overview	30
<b>TROUBLESHOOTING</b>	<b>32</b>
Troubleshooting Tips	32
<b>SERVICE</b>	<b>33</b>
<b>MOUNTING DIMENSIONS</b>	<b>34</b>
<b>EC DECLARATION OF CONFORMITY</b>	<b>35</b>

## Table of Figures

Figure 1: Integrated Vigilante II (PD8-154-6 & PD8-158-6) Required Connections.....	15
Figure 2: Integrated Vigilante II (PD8-154-7 & PD8-158-7) Required Connections.....	16
Figure 3: Integrated Trident X2 (PD8-765) Required Connections.....	17
Figure 4: Integrated High Voltage Snoopers (PD8-865-6) Required Connections.....	18
Figure 5: Integrated Low Voltage Snoopers (PD8-865-7) Required Connections.....	19
Figure 6: Integrated ProVu Required Connections.....	20
Figure 7: Digital I/O Connections.....	21
Figure 8: External Switch Contacts .....	23
Figure 9: ProtEX-MAX Connections to a Serial Converter .....	24
Figure 10: RS-485 Wiring.....	25
Figure 11: RS-485 Two-Wire Multi-Drop Wiring.....	26
Figure 12: General Four-Wire Network Connection .....	31
Figure 13: General Two-Wire Network Connection .....	31
Figure 14: Enclosure Dimensions – Front View .....	34
Figure 15: Enclosure Dimensions – Side Cross Section View.....	34

# SPECIFICATIONS

Except where noted all specifications apply to operation at +25°C.

## Instrument Specifications

Refer to the data sheet and manual for the meter/controller integrated to the PD8.

### General

---

<b>CONNECTIONS</b>	Screw terminals accept 12 to 22 AWG wire
<b>ENCLOSURE</b>	Explosion-proof die cast aluminum with glass window, corrosion resistant epoxy coating, color: blue. NEMA 4X, 7, & 9, IP68. Default conduit connections: Four ¾" NPT threaded conduit openings and two ¾" NPT metal conduit plugs with 12 mm hex key fitting installed. Additional conduit opening configurations may be available; verify quantity and sizes on specific device labeling during installation.
<b>MOUNTING</b>	Four slotted flanges for wall mounting or NPS 1½" to 2½" or DN 40 to 65 mm pipe mounting. See Mounting Dimensions on page 34.
<b>OVERALL DIMENSIONS</b>	6.42" x 7.97" x 8.47" (W x H x D) (163 mm x 202 mm x 215 mm)
<b>APPROXIMATE SHIPPING WEIGHT</b>	16.0 lbs (7.26 kg)
<b>WARRANTY</b>	3 years parts and labor

---

### Serial Communications

These specifications are not applicable to PD8-154 and PD8-154 series, which have no serial communications, or PD8-865 models where serial communications is standard. Additional information can be found in the PD865 instruction manual.

<b>COMPATIBILITY</b>	EIA-485
<b>CONNECTORS</b>	Removable screw terminal connector
<b>MAX DISTANCE</b>	3,937' (1,200 m) max
<b>STATUS INDICATION</b>	Separate LEDs for Power (P), Transmit (TX), and Receive (RX)

---

### Digital Inputs & Outputs

Note: PD8 Series PROVu integrated functionality models only.

See notices and warnings on page 21.

---

<b>CHANNELS</b>	4 digital inputs & 4 digital outputs per module
<b>SYSTEM</b>	One expansion module may be added for a total of 8 inputs & 8 outputs <i>Note: The jumper located between the RJ45 connectors must be removed on the expansion module.</i>
<b>DIGITAL INPUT LOGIC HIGH</b>	3 to 5 VDC
<b>DIGITAL INPUT LOGIC LOW</b>	0 to 1.25 VDC
<b>DIGITAL OUTPUT LOGIC HIGH</b>	3.1 to 3.3 VDC
<b>DIGITAL OUTPUT LOGIC LOW</b>	0 to 0.4 VDC
<b>SOURCE CURRENT</b>	10 mA maximum output current
<b>SINK CURRENT</b>	1.5 mA minimum input current

---

**+5 V  
TERMINAL**

To be used as pull-up for digital inputs only.  
Connect normally open pushbuttons across +5 V & DI 1-4.



*DO NOT use +5 V terminal (pin 1) to power external devices.*

**WARNING**

---

### External Switch Contacts

PD8-765 Series Trident X2 integrated functionality models only. See Vigilante II Instruction Manual for information on PD8-154 and PD8-158 Series external switch contact specifications.

---

<b>Open State</b>	+5 VDC open contact on switch input terminals
<b>Closed State</b>	Closed contact switch input terminal to common/ground, active low 0 to 0.4 VDC, or open collector transistor activated input

---



## Product Ratings and Approvals;

---

<b>FM</b>	Enclosure: Type 4X; IP66 Class I, Division 1, Groups B, C, D Class II, Division 1, Groups E, F, G Class III, Division 1, T5/T6 Class I, Zone 1, AEx d, IIC Gb T5/T6 Zone 21, AEx tb IIIC T90°C; Ta -40°C to +65°C T6 Ta = -40°C to +60°C; T5 Ta = -40°C to +65°C Certificate Number: 3047283
<b>CSA</b>	Class I, Division 1, Groups B, C, D Class II, Division 1, Groups E, F, G Class III, Division 1 Class I Zone 1 Ex d IIC Zone 21 Ex tb IIIC T90°C -40°C < Tamb. < +60° C; Temperature Code T6 -40°C < Tamb. < +65° C; Temperature Code T5 Enclosure Type 4X & IP66 Certificate Number: 2531731
<b>ATEX</b>	 II 2 G D Ex d IIC T* Gb Ex tb IIIC T90°C Db IP68 Ta = -40°C to +*°C *T6 = -40°C to +60°C *T5 = -40°C to +65°C Certificate number: Sira 12ATEX1182
<b>IECEX</b>	Ex d IIC T* Gb Ex tb IIIC T90°C Db IP68 Ta = -40°C to +*°C *T6 = -40°C to +60°C *T5 = -40°C to +65°C Certificate Number: IECEX SIR 12.0073

---

### ***Special Conditions for Safe Use:***

Use suitably certified and dimensioned cable entry device and/or plug. The equipment shall be installed such that the supply cable is protected from mechanical damage. The cable shall not be subjected to tension or torque. If the cable is to be terminated within an explosive atmosphere, then appropriate protection of the free end of the cable shall be provided. Cable must be suitable for 90°C.

### ***Year of Construction***

This information is contained within the serial number with the first four digits representing the year and month in the YYMM format.

***For European Community:*** The ProtEX-MAX must be installed in accordance with the ATEX directive 94/9/EC, and the product certificate Sira 12ATEX1182.

## **Electromagnetic Compatibility**

---

<b>EMISSIONS</b>	EN 55022:2006/A1:2007 Class A ITE emissions requirements
Radiated Emissions	Class A
AC Mains Conducted Emissions	Class A
<b>IMMUNITY</b>	EN 61326-1:2006 Measurement, control, and laboratory equipment EN 61000-6-2:2005 EMC heavy industrial generic immunity standard
RFI - Amplitude Modulated	80 -1000 MHz 10 V/m 80% AM (1 kHz) 1.4 - 2.0 GHz 10 V/m 80% AM (1 kHz) 2.0 - 2.7 GHz 10 V/m 80% AM (1 kHz)
Electrical Fast Transients	±2 kV AC mains, ±1kV other
Electrostatic Discharge	±4 kV contact, ±8kV air
RFI - Conducted	10 V, 0.15-80 MHz, 1kHz 80% AM
AC Surge	±2 kV Common, ±1kV Differential
Surge	1 kV (CM)
Power-Frequency Magnetic Field	3 A/m 70%V for 0.5 period
Voltage Dips	40% V for 5 & 50 periods 70% V for 25 periods
Voltage Interruptions	<5% V for 250 periods

---

## SAFETY INFORMATION



### WARNINGS

- Read complete instructions prior to installation and operation of the instrument.
- Installation and service should be performed only by trained service personnel. Service requiring replacement of internal sub-components must be performed at the factory.
- Disconnect from supply before opening enclosure. Keep cover tight while circuits are alive. Conduit seals must be installed within 18" (450mm) of the enclosure or within 2" (50mm) for Zone installations.
- Verify that the operating atmosphere of the instrument is consistent with the appropriate hazardous locations certifications.
- If the instrument is installed in a high voltage environment and a fault or installation error occurs, high voltage may be present on any lead
- Read all product labels completely and follow all instructions and requirements listed on the labels for installation or service.

## INSTALLATION

*Install in accordance with applicable local and national regulations (e.g. NEC).*

**For Installation in USA:** The ProtEX-MAX must be installed in accordance with the National Electrical Code (NEC) NFPA 70.

**For Installation in Canada:** The ProtEX-MAX must be installed in accordance with the Canadian Electrical Code CSA 22.1. All power supplies below 36 V and input circuits must be derived from a CSA Approved Class 2 source.

**For European Community:** The ProtEX-MAX must be installed in accordance with the ATEX directive 94/9/EC and the product certificate Sira 12ATEX1182.



### WARNING

Disconnect from supply before opening enclosure. Keep cover tight while circuits are alive. Conduit seals must be installed within 18" (450mm) of the enclosure or within 2" (50mm) for Zone installations.

Wiring connectors are accessed by opening the enclosure. To access electrical connectors, remove the 2 captive screws and then remove the electronics module. Connectors are on the rear of the electronics module.

### Unpacking

Remove the instrument from packing box. Inspect the packaging and contents for damage. Report damages, if any, to the carrier.

If any part is missing or the instrument malfunctions, please contact your supplier or the factory for assistance.

### Pre-Installed Conduit/Stopping Plug

The PD8 Series is supplied with two pre-installed conduit plugs for installations that do not require the use of all conduit entries. The conduit/stopping plugs include an internal 12mm hexagonal socket recess for removal. The pre-installed plugs and their installation are included in the hazardous area approvals for the PD8 Series enclosure.



**WARNING**

In hazardous areas, conduit and conduit/stopping plugs require the application of non-setting (solvent free) thread sealant. It is critical that all relevant hazardous area guidelines be followed for the installation or replacement of conduit or plugs.

### Mounting

The ProtEX-MAX Series has four slotted mounting flanges that should be used for pipe mounting or wall mounting.

Refer to *Mounting Dimensions*, page 34 for details.



**WARNING**

Do not attempt to loosen or remove flange bolts while the instrument is in service.

### Cover Jam Screw

The cover jam screw should be properly installed once the instrument has been wired and tested in a safe environment. The cover jam screw is intended to prevent the removal of the instrument cover in a flameproof environment without the use of tools. Using a M2 hex wrench, turn the screw clockwise until the screw contacts the aluminum enclosure. Turn the screw an additional 1/4 to 1/2 turn to secure the cover. Caution: Excess torque may damage the threads and/or wrench.

# CONNECTIONS



### WARNINGS

- Static electricity can damage sensitive components.
- Observe safe handling precautions for static-sensitive components.
- Use proper grounding procedures/codes.
- If the instrument is installed in a high voltage environment and a fault or installation error occurs, high voltage may be present on any lead or terminal.
- Follow all fusing and wiring precautions requirements for the instrument integrated to the PD8 Series model number being connected.

To access the connectors, remove the enclosure cover and unscrew the two captive screws that fasten the electronics module. Signal connections are made to de-pluggable connectors on the back of the electronics module.

Some connectors may be provided already connected. These connections are required for proper operation of the ProtEX-MAX, and should not be removed unless instructed to by this manual.

Wires marked as being used for testing purposes should be removed.

Grounding connections are made to the two ground screws provided on the base – one internal and one external.

After all connections have been completed and verified, apply power to the unit.

## Required & Factory Wired Connections

The ProtEX-MAX comes with several pre-wired connections. These connections are detailed below, and must be maintained in order for the instrument to function properly.

In addition, low voltage powered Snooper integrated models (PD8-865-7 models) require power to be wired to the ProtEX-MAX connector board.

For details on the required wiring to maintain basic ProtEX-MAX functions, refer to the appropriate below section for the specific ProtEX-MAX model number.



### WARNING

Observe all safety regulations. Electrical wiring should be performed in accordance with all agency requirements and applicable national, state, and local codes to prevent damage to the meter and ensure personnel safety.

### Required Connections on PD8-154-6 and PD8-158-6 Series Models

ProtEX-MAX units with Vigilante II integrated functionality have two factory wired connectors. Four wires connect the remote switch inputs of the annunciator. Two wires connect the DC power supply on the main meter electronics to the ProtEX-MAX connector board. These must remain connected as shown for the SafeTouch Buttons to function on these models.



#### NOTICE

The connections described in this section must remain connected for the SafeTouch buttons to function.

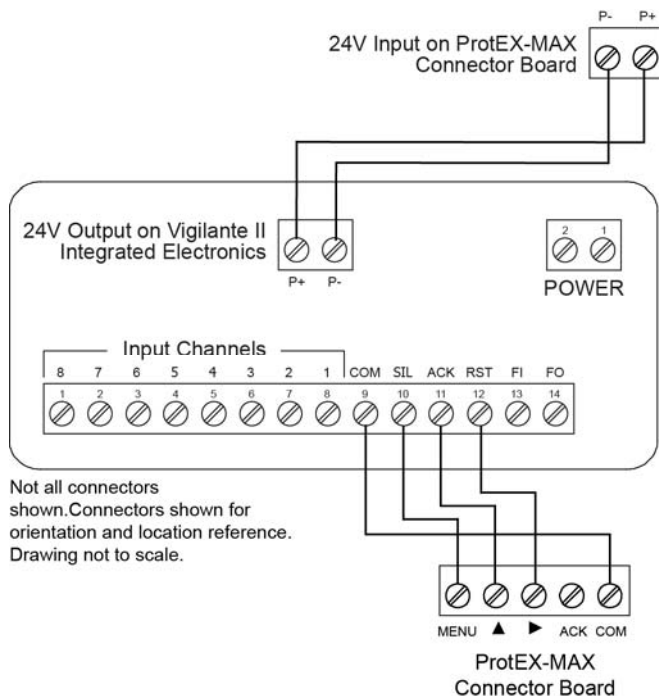

Figure 1: Integrated Vigilante II (PD8-154-6 & PD8-158-6) Required Connections

## PD8 Series Explosion-Proof Instrument Supplemental Manual

### Required Connections on PD8-154-7 and PD8-158-7 Series Models

Low voltage PD8-154-7 and PD8-158-7 models require low voltage power to be supplied to the power supply connector on the ProtEX-MAX connector board as well as to the integrated Vigilante II connections as described in the Vigilante II Instruction Manual.

In addition, four wires connect the remote switch inputs of the annunciator to the ProtEX-MAX connector board. These wires must remain connected for the SafeTouch buttons to function.



**NOTICE**

The connections described in this section must remain connected for the SafeTouch buttons to function.

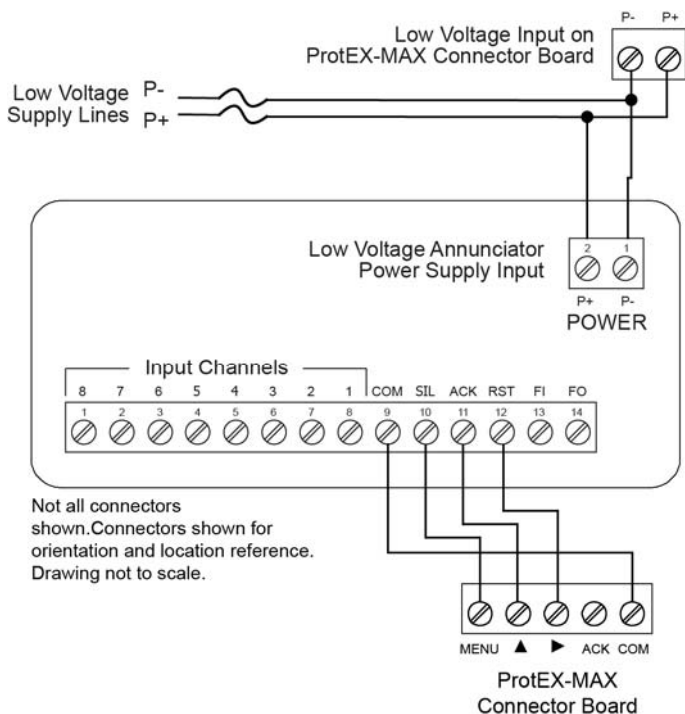

Figure 2: Integrated Vigilante II (PD8-154-7 & PD8-158-7) Required Connections



### Required Connections on PD8-765 Series Models

ProtEX-MAX units with Trident X2 integrated functionality have two factory wired connectors. A modular cable must connect from the rear of the integrated Trident X2 electronics to the ProtEX-MAX connector board. The Trident X2 integrated models also have a 5 position external switch connector wired from the rear of the integrated Trident X2 electronics to the ProtEX-MAX connector board as shown below. This must remain connected as shown to the ProtEX-MAX connector board for the SafeTouch Buttons to function on these models.



#### NOTICE

The connections described in this section must remain connected for the SafeTouch buttons to function.

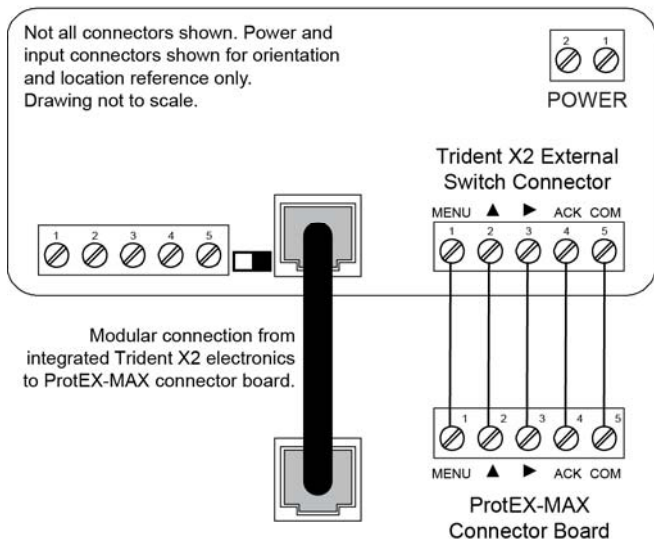

Figure 3: Integrated Trident X2 (PD8-765) Required Connections

### Required Connections on PD8-865-6 Series Models

High voltage PD8-865-6 models have a power connector attached to the P+ and P- labeled 24 VDC power supply of the unit and connected to the ProtEX-MAX connector board. Other devices may be connected in parallel with this power supply connection, but the power supply connection to the ProtEX-MAX connector board must remain for the SafeTouch buttons to function on these models.

In addition, internal wiring connects externally to a 5 position connector on the ProtEX-MAX connector board. These wires must remain connected for the SafeTouch buttons to function. To disable the SafeTouch buttons on the PD8-865, the switch connector must be removed.



#### NOTICE

The connections described in this section must remain connected for the SafeTouch buttons to function.

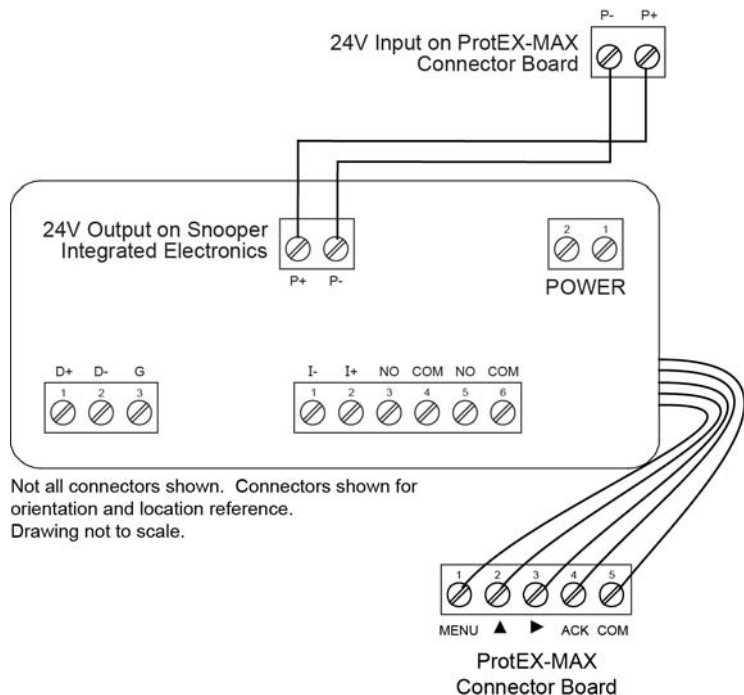

Figure 4: Integrated High Voltage Snooper (PD8-865-6) Required Connections

## PD8 Series Explosion-Proof Instrument Supplemental Manual

### Required Connections on PD8-865-7 Series Models

Low voltage PD8-865-7 models require low voltage power to be supplied to the power supply connector on the ProtEX-MAX connector board as well as to the integrated PD865 Snooper as described in the PD865 Instruction Manual.

In addition, internal wiring connects externally to a 5 position connector on the ProtEX-MAX connector board. These wires must remain connected for the SafeTouch buttons to function. To disable the SafeTouch buttons on the PD8-865, the switch connector must be removed.



**NOTICE**

The connections described in this section must remain connected for the SafeTouch buttons to function.

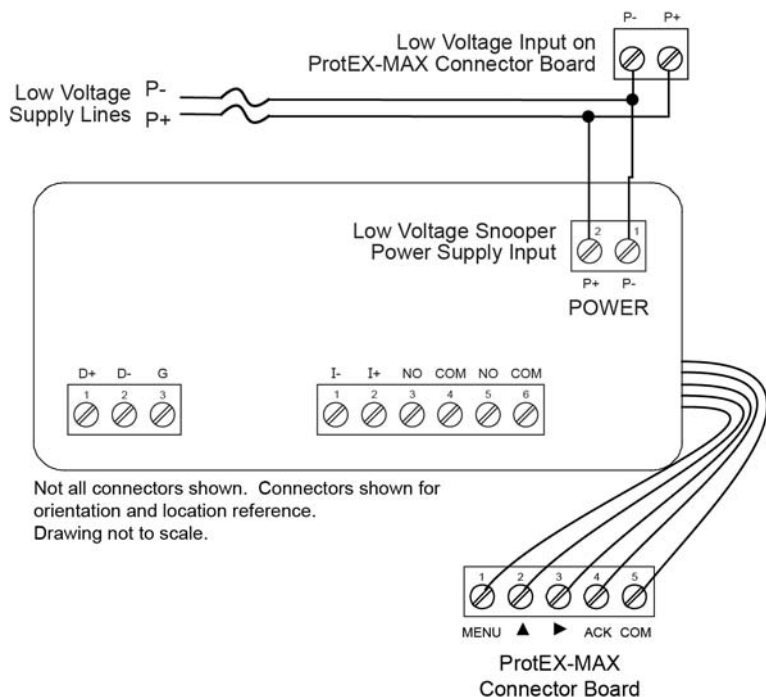
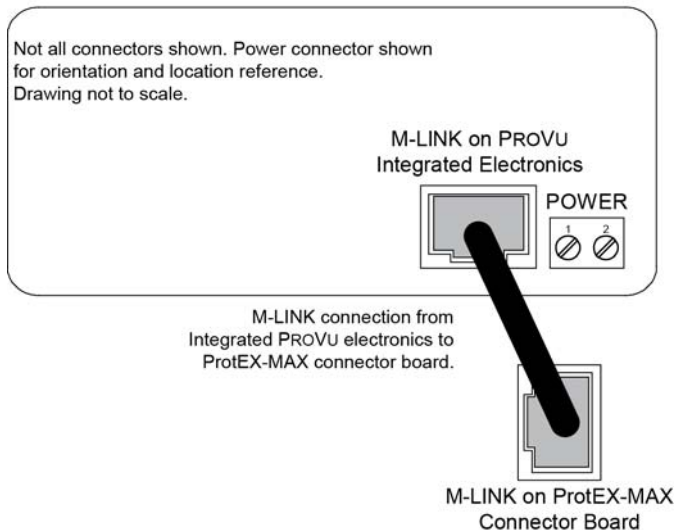

**Figure 5: Integrated Low Voltage Snooper (PD8-865-7) Required Connections**

## PD8 Series Explosion-Proof Instrument Supplemental Manual

Factory Connections on **PD8-6000, PD8-6060, PD8-6100, PD8-6200, PD8-6210, PD8-6300, PD8-6310, and PD8-7000 Series Models**

One factory installed M-LINK cable connects the integrated PROVU electronics to the ProtEX-MAX connector board.



**Figure 6: Integrated PROVU Required Connections**

## Digital I/O Connections

ProtEX-MAX models with integrated PROVu functionality have a 10 position terminal block for connecting the digital inputs and outputs. See Model Number Descriptions on page 4 for details on ProtEX-MAX integrated instruments.

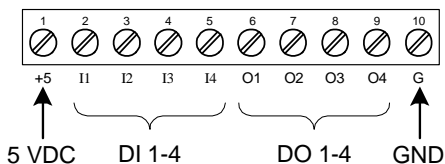

**Figure 7: Digital I/O Connections**  
(PROVu Integrated Instruments Only)



**NOTICE**

The digital inputs are configured at the factory to function identically to the front panel pushbuttons in order to work with the Safe-Touch buttons. Changing the programming of the digital inputs will affect the function of the SafeTouch buttons.



**WARNING**

Observe all safety regulations. Electrical wiring should be performed in accordance with all agency requirements and applicable national, state, and local codes to prevent damage to the meter and ensure personnel safety.

### External Switch Contacts

ProtEX-MAX models with integrated Vigilante II, PROVu, or Trident X2 may be wired with external switch contacts. See Model Number Descriptions on page 4 for details on ProtEX-MAX integrated instruments.

#### For Vigilante II Integrated Functionality Instruments

The ProtEX-MAX includes a removable screw terminal connector with external switch contacts. See the Vigilante II instruction manual for more information on connecting these external switch contacts.

#### For PROVu Integrated Functionality Instruments

The ProtEX-MAX includes 4 digital inputs. These digital inputs are preconfigured at the factory to function as external contacts to duplicate the front button functions of the instrument. The factory configuration uses the following corresponding digital input terminals for external switch contacts.

Digital Input Connection	Factory Default Function
I1	MENU
I2	RIGHT arrow
I3	UP arrow
I4	ENTER arrow

See Digital Inputs & Outputs in the Specification on page 8 for details on the digital inputs.



#### NOTICE

The digital inputs are configured at the factory to function identically to the front panel pushbuttons in order to work with the Safe-Touch buttons. Changing the programming of the digital inputs will affect the function of the SafeTouch buttons.

### For Trident X2 Integrated Functionality Instruments

The ProtEX-MAX includes a removable screw terminal connector for external switch contacts. External switch contacts may be wired across the switch contact and COM on the connector labeled Trident X2 External Switch Connections in the Figure below.

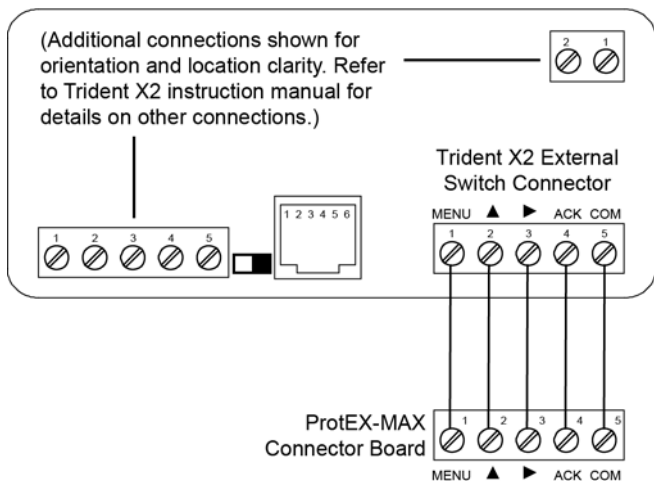

**Figure 8: External Switch Contacts**  
(Trident X2 Integrated Instruments Only)



Removing the connectors or changing the default wiring of the ProtEX-MAX external switch connectors will affect the function of the SafeTouch buttons.



See External Switch Contacts in the Specification on page 8 for electrical specifications for using the external switch contacts.

## Serial Communications Connections

ProtEX-MAX instruments with integrated PROVU and Trident X2 functionality have a 5 position terminal block for connecting RS-485 serial devices. Snooper integrated models have an RS-485 connection on the rectangular far rear section of the electronics module, and information on these connections can be found in the Snooper instruction manual included with the ProtEX-MAX. See Model Number Descriptions on page 4 for details on ProtEX-MAX integrated instruments.

Vigilante II integrated models do not have serial communications.

Figure 9 details the wiring connections from the ProtEX-MAX to an RS-485 serial converter (such as the PDA7485 or PDA8485) for a four-wire network.

ProtEX-MAX to RS-485 Serial Converter Connections	
RS-485 Serial Converter	ProtEX-MAX RS-485 Connections
	
$\overline{\text{DO}}$	$\overline{\text{DI}}$
DO	DI
$\overline{\text{DI}}$	$\overline{\text{DO}}$
DI	DO

**Figure 9: ProtEX-MAX Connections to a Serial Converter**  
(PROVU & Trident X2 Integrated Instruments Only)

Baud rates are adjustable and handled by the PROVU or Trident X2 (see the included manuals for more details on programming the serial communications settings).

The ProtEX-MAX has three diagnostic LEDs: a Power (P) LED to show when the module is powered properly, a Transmit Data (TX) LED to show when the module is being transmitted to by the PC side, and a Receive Data (RX) LED to show when the module is sending data to a receiving device.

The following diagrams detail how to connect the RS-485 serial communications from the ProtEX-MAX to a RS-485/RS-232 serial converter (PDA7485) in four wire and two wire configurations.



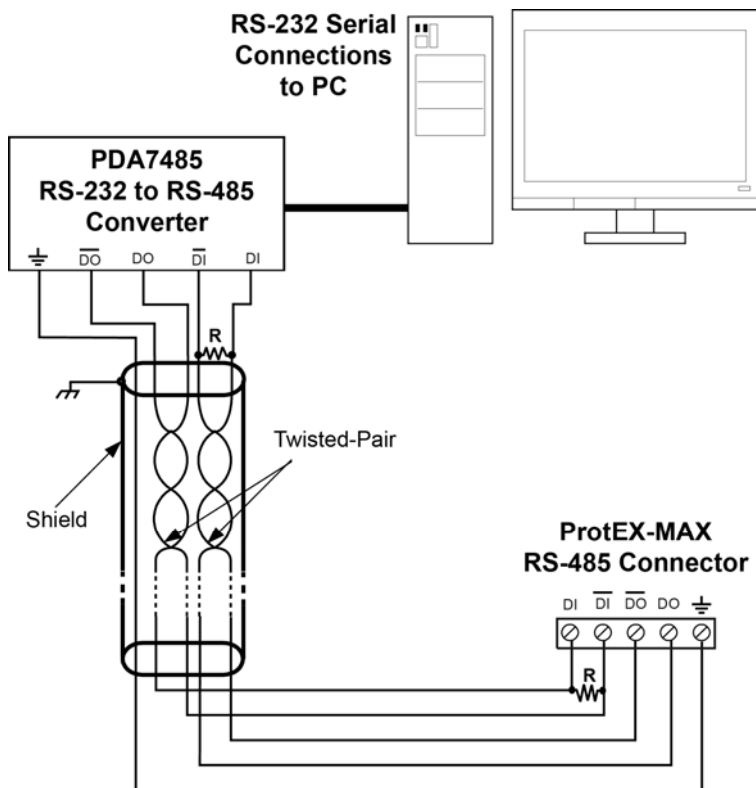

Figure 10: RS-485 Wiring

**Notes:**

1. Termination resistors are optional and values depend on the cable length and characteristic impedance. Consult the cable manufacturer for recommendations.
2. Refer to RS-232 to RS-485 Converter documentation for further details.
3. Use shielded cable, twisted-pairs plus ground. Connect ground shield only at one location.



Observe all safety regulations. Electrical wiring should be performed in accordance with all agency requirements and applicable national, state, and local codes to prevent damage to the meter and ensure personnel safety.

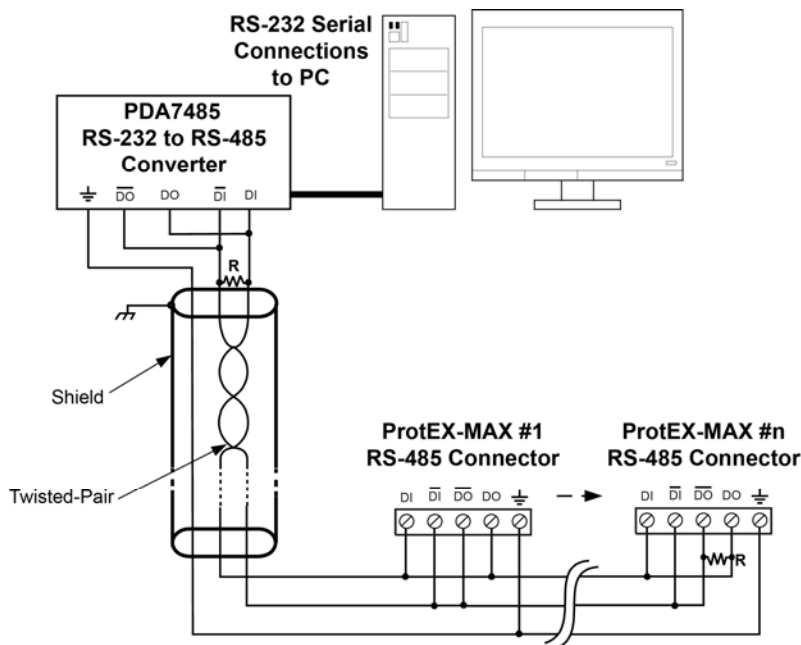

**Figure 11: RS-485 Two-Wire Multi-Drop Wiring**

**Notes:**

1. Termination resistors are optional and values depend on the cable length and characteristic impedance. Consult the cable manufacturer for recommendations.
2. Refer to RS-232 to RS-485 Converter documentation for further details.
3. Use shielded cable, twisted-pair plus ground. Connect ground shield only at one location.



Observe all safety regulations. Electrical wiring should be performed in accordance with all agency requirements and applicable national, state, and local codes to prevent damage to the meter and ensure personnel safety.

When using more than one instrument in a multi-drop or multi-point mode, each meter must be provided with its own unique address. Refer to the PROVu, Trident X2, or Snooper instruction manual included with this ProtEX-MAX for information on how to change the communication address.

### Using PROVu Serial Adapters

**NOTICE**

PROVu expansion modules and serial adapters are not included in the hazardous area approvals of the ProtEX-MAX. The PDA1232 and PDA8008 may be used only while the ProtEX-MAX is in a safe area, and will disable some features while installed.

PROVu expansion modules and serial adapters are not recommended for use with the ProtEX-MAX. It is recommended that any serial protocol conversion required on the RS-485 communications connection be performed using a PDA7485 RS-232 to RS-485 or PDA8485 USB to RS-485 serial converter located in a safe area.

# OPERATION

## Overview

The following instructions detail the operation of features specific to the ProtEX-MAX. For information on using the features of the integrated meter or controller, including instrument programming, configuration, input, output, or display features, see the PROVu, Trident X2, Snooper, or Vigilante II instruction manual.

Setup and programming may be done through the infrared through-glass SafeTouch buttons, or using the mechanical buttons when uncovered. There is a slide switch located on the connector board. This is used to enable or disable SafeTouch Buttons.

## SafeTouch Buttons

The ProtEX-MAX is equipped with four sensors that operate as through-glass buttons so that it can be programmed and operated without removing the cover (and exposing the electronics) in a hazardous area.

These buttons can be disabled for security by selecting DISABLE on the switch labeled NO-CONTACT BUTTONS located on the connector board.

To actuate a button, press one finger to the glass directly over the marked button area. Then retract finger more than three inches from the glass before pressing the next button. When the cover is removed, the four mechanical buttons located next to the sensors are used. The sensors are disabled when a mechanical button is pressed and will automatically be re-enabled after 60 seconds of inactivity.

The SafeTouch Buttons are designed to filter normal levels of ambient interference and to protect against false triggering, however, it is recommended that the SafeTouch Buttons be disabled (slide switch to LOCK) if there is an infrared interference source in line-of-sight to the display.

The SafeTouch Buttons are configured by default to duplicate the function of the front panel mechanical pushbuttons associated with the integrated meter. The symbols by each SafeTouch button correspond to a mechanical button. Operation of the instrument is performed as described in the PROVu, Trident X2, Snooper or Vigilante II instruction manual included with the ProtEX-MAX.

### SafeTouch Button Tips:

- To the extent possible, install the display facing away from sunlight, windows, reflective objects and any sources of infrared interference.
- Keep the glass window clean.
- Tighten the cover securely.
- Use a password to prevent tampering.



**WARNING**

Take caution when cleaning the window glass as it may result in unintentional SafeTouch button events. Only clean the ProtEX-MAX when the system is safely shut down, and inspect the ProtEX-MAX for proper configuration prior to system restart.

### Digital I/O

Digital inputs and outputs are only present on ProtEX-MAX models with integrated PROVu functionality. See Model Number Descriptions on page 4 for details on which instruments qualify.

The ProtEX-MAX has four digital inputs and four digital outputs. External digital inputs can function similarly to the front panel function keys.

**NOTICE**

The digital inputs are configured at the factory to function identically to the front panel pushbuttons in order to work with the Safe-Touch buttons. Changing the programming of the digital inputs will affect the function of the SafeTouch buttons.

They can be configured to trigger certain events (i.e. acknowledge/reset alarms, reset max and/or min values, disable/enable all output relays, and hold current relay states), provide direct menu access point, or mimic front panel keys.

Digital outputs can be used to remotely monitor alarm relay output states, or the states of a variety of actions and functions executed by the meter.

See the PROVu Instruction Manual included with this instrument for details on programming the Digital I/O.

### Serial Communications Overview

RS-232 and RS-485 are standard interfaces approved by the Electronic Industries Alliance (EIA) for connecting serial devices. In EIA terms, the device (e.g. meter) that connects to the interface is called a Data Communications Equipment (DCE) and the device to which it connects (e.g. the computer) is called a Data Terminal Equipment (DTE).

RS-485 can support multi-point connections per line because it uses lower-impedance drivers and receivers.

Line drivers and receivers are used to exchange data between two or more points (nodes) on a serial communications network. Reliable data communications can be difficult in the presence of induced noise, ground level differences, and other hazards associated with installation of a network. When communicating at high data rates, or over long distances in real world environments, RS-232 is often inadequate. The differential data transmission of RS-485 offers superior performance in most applications. Differential signals can help nullify the effects of ground shifts and induced noise signals that can appear as common mode voltages on a network.

A multi-point network consists of multiple drivers and receivers connected on a single bus, where any point (node) can transmit and/or receive data. RS-485 allows multiple drivers and receivers on the same two-wire or four-wire system. The RS-485 standard specifies up to 32 drivers and 32 receivers on a single bus, but with the introduction of "automatic" repeaters and high-impedance drivers/receivers, this number can be extended to hundreds of points (nodes) on a network.

## PD8 Series Explosion-Proof Instrument Supplemental Manual

The cabling used for an RS-485 serial communications network should always be a high quality cable such as Belden 8162 or Alpha 6203C. A two-wire system requires two twisted pairs, and a four-wire system requires three twisted pairs (the extra twisted pair is needed for the signal ground).

Figure 12 illustrates how to connect a general four-wire network (a four-wire network actually contains 5 wires).

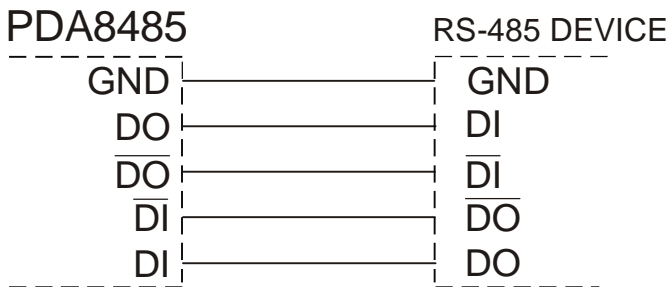

**Figure 12: General Four-Wire Network Connection**

Figure 13 illustrates how to connect a general two-wire network (a two-wire network actually contains 3 wires). Note that the PDA7485 and PDA8485 have DIP switches that allow for two-wire connections without the need to externally wire the DO to the DI and the  $\overline{\text{DO}}$  to the  $\overline{\text{DI}}$  (see the converter section for complete details).

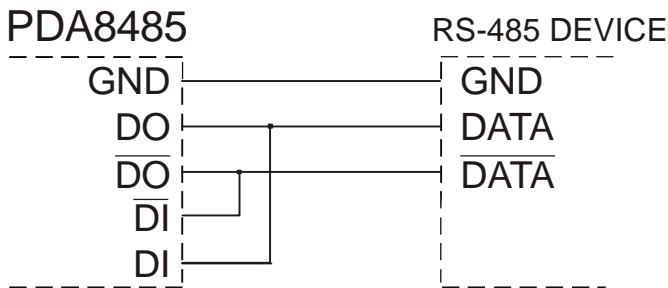

**Figure 13: General Two-Wire Network Connection**

## TROUBLESHOOTING

The ProtEX-MAX rugged design should make it unusual for the installer or operator to refer to this section of the manual. If the instrument is not working as expected, refer to the recommendations below.

### Troubleshooting Tips

Symptom	Check/Action
SafeTouch buttons do not respond	<p>If mechanical button was pushed. The SafeTouch buttons will be re-enabled automatically <b>60 seconds</b> after the last button push.</p> <p>If slide switch on connector board is in DISABLE position, switch to ENABLE.</p> <p>Strong direct sunlight may interfere with SafeTouch button operation. It is recommended to operate the buttons by standing so as to block direct sunlight.</p>
Serial Communications Power LED Indicator is off	<ol style="list-style-type: none"> <li>1. Check modular cable connection</li> <li>2. Check power to the device</li> </ol>
Meter not communicating with MeterView, MeterView Pro, or other programs	<ol style="list-style-type: none"> <li>1. Check serial cable</li> <li>2. Check protocol selected on device</li> <li>3. Check instrument address &amp; baud rate</li> <li>4. Check program address &amp; baud rate</li> </ol>
If only the TX (or DATA IN) data status LED is flashing when serial communications attempted	<ol style="list-style-type: none"> <li>1. Check serial cable</li> <li>2. Check protocol selected on device</li> <li>3. Check instrument address &amp; baud rate</li> <li>4. Check program address &amp; baud rate</li> </ol>
If both data status LEDs (TX and RX) are off when trying to communicate	<p>Remove all unnecessary cables and instruments from the bus. Try getting the system to work with only one device (to ease troubleshooting) and then expand the system one device at a time.</p>
Communications slow	<p>Increase the baud rate</p>
Random communication errors	<ol style="list-style-type: none"> <li>1. Increase the TX delay time</li> <li>2. Decrease the baud rate</li> </ol>
Power LED is off	<ol style="list-style-type: none"> <li>1. Check modular cable connection</li> <li>2. Check power to instrument</li> </ol>
Other symptoms not described above	<p>Call Technical Support for assistance or the instruction manual included with this ProtEX-MAX.</p>



### SERVICE



#### WARNINGS

- Installation and service should be performed only by trained service personnel. Service requiring replacement of internal sub-components must be performed at the factory.
- Disconnect from supply before opening enclosure. Keep cover tight while circuits are alive. Conduit seals must be installed within 18" (450mm) of the enclosure.
- Verify that the operating atmosphere of the instrument is consistent with the appropriate hazardous locations certifications.
- If the instrument is installed in a high voltage environment and a fault or installation error occurs, high voltage may be present on any lead
- Read all product labels completely and follow all instructions and requirements listed on the labels for installation or service.

If the enclosure is sound and undamaged, then only the internal electronics housing will need to be returned to the factory for service. Contact the factory for RMA number and return instructions.

## MOUNTING DIMENSIONS

All units: inches (mm)

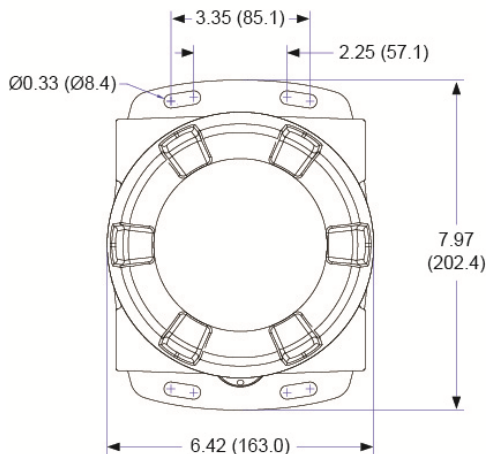

Figure 14: Enclosure Dimensions – Front View

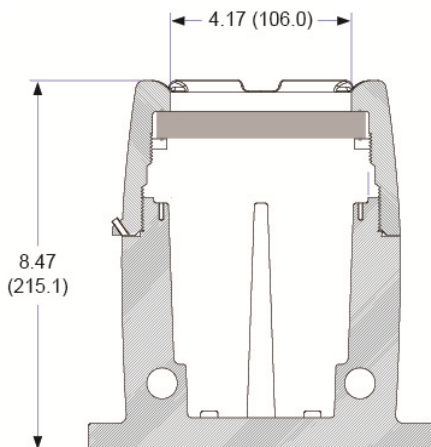

Figure 15: Enclosure Dimensions – Side Cross Section View



## EC DECLARATION OF CONFORMITY

Issued in accordance with ATEX Directive 94/9/EC

Manufacturer: Precision Digital Corporation  
89 October Hill Rd Ste 5  
Holliston, MA 01746 USA

Device: PD8 Series Device

Notified Body: Sira Certification Service, notified body no. 0518  
Rake Lane, Eccleston, Chester, CH4 9JN, England

EC Type Examination Certificate: Sira 12ATEX1182

Quality Assurance Notification No.: SIRA 10 ATEX M462

Compliance with Standards:

EN 60079-0:2009  
EN 60079-1:2007  
EN 60079-31:2008  
EN 61326:2006

Product Markings:

 II 2GD  
Ex d IIC T\* Gb  
Ex tb IIIC T90°C Db IP68  
Ta = -40°C to +\*°C  
\*T6 = -40°C to +60°C  
\*T5 = -40°C to +65°C

Community Directives:

94/9/EC            ATEX Directive  
2004/108/EC    EMC Directive

Name: Jeffrey Peters  
Company: Precision Digital Corporation  
Title: President  
Date: 10/19/2012

## How to Contact Precision Digital

- For Technical Support:  
Call: (800) 610-5239 or (508) 655-7300  
Fax: (508) 655-8990  
Email: [support@predig.com](mailto:support@predig.com)
- For Sales Support:  
Call: (800) 343-1001 or (508) 655-7300  
Fax: (508) 655-8990  
Email: [sales@predig.com](mailto:sales@predig.com)
- For the latest version of this manual please visit:  
**[www.predig.com](http://www.predig.com)**